

APTC M900
Woodturning Lathe

INSTRUCTION

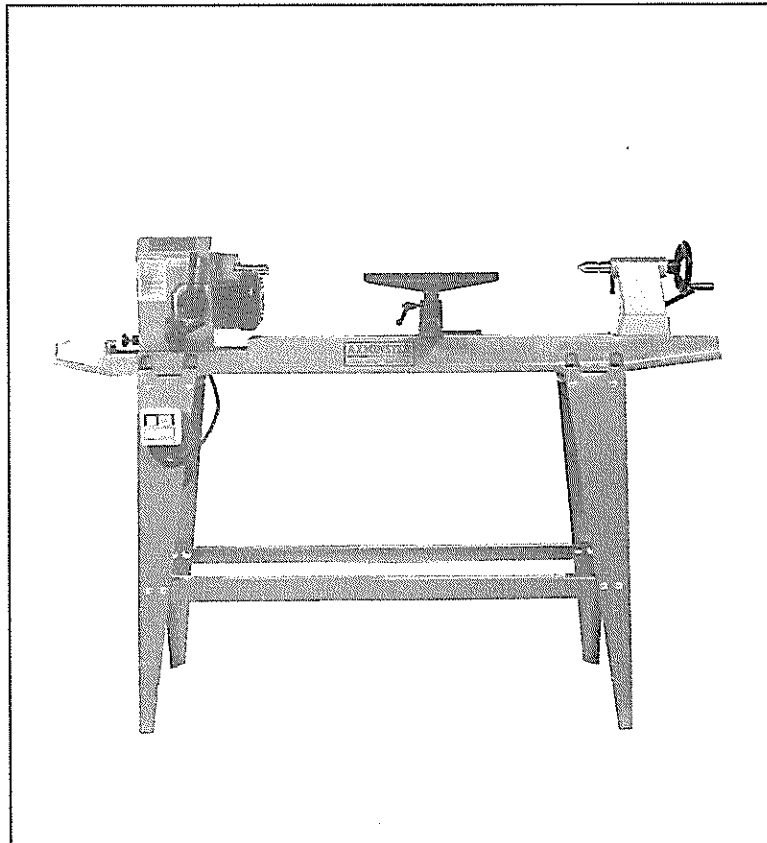

MANUAL

AXMINSTER
POWER TOOL CENTRE

GENERAL SAFETY INSTRUCTIONS FOR MACHINE TOOLS

KNOW YOUR MACHINE TOOL

Read and understand the owner's manual and labels affixed to the tool. Learn its application and limitations as well as specific potential hazards peculiar to the tool.

EARTH ALL TOOLS

This tool is equipped with an approved 3 core cable. The green and yellow conductor in the core is the earth wire. NEVER connect the green and yellow wire to a live terminal.

KEEP GUARDS IN PLACE

Keep all guards in place. They are there for your protection and do not interfere with the correct operation of your machine.

REMOVE ADJUSTING KEYS AND WRENCHES

Form a habit of checking to see that keys and adjusting wrenches are removed from tool before turning it on.

KEEP WORK AREA CLEAN

Cluttered areas and benches invite accidents. Floors must not be slippery due to oil or sawdust. Make sure you clean up any waste materials on completion of any jobs.

AVOID DANGEROUS ENVIRONMENTS

Do not use power tools in damp or wet locations or expose them to rain. Keep work area well lit. Provide adequate surrounding work area.

KEEP CHILDREN AWAY

All visitors should be kept a safe distance from work area. Children are naturally curious therefore ensure they are closely supervised when they are near the work area.

MAKE WORKSHOP CHILDPROOF

Many machines have lockable switches that can be secured with a small padlock or have a removable key. Please make use of them to prevent unauthorised operation of your machines.

DO NOT FORCE TOOL

It will do the job better and safer at the rate for which it was designed. Develop a patient approach to the work, you will get a better result in the finished product.

WEAR PROPER CLOTHING

Do not wear loose clothing, gloves, neckties or jewellery that can catch in moving parts of machinery. Non-slip footwear with steel toecaps is recommended. Wear protective hair covering to contain long hair. Roll up long sleeves above the elbow.

SECURE WORK

Use clamps or a vice where applicable to hold work. This frees both hands to operate tool correctly and thus produces better results.

DIRECTION OF FEED

Feed work into a blade or cutter against the direction of rotation of the blade or cutter only. This will reduce the danger of kick back which is a serious hazard.

USE SAFETY GOGGLES AND FACE PROTECTION

Wear safety goggles (complying to relevant standards) at all times. Normal spectacles only have impact resistant lenses and are NOT sufficient. Also use face or dust masks if cutting operation is dusty (connection of machine to a dust extractor is preferred). Always wear ear protectors for cutting, sawing, planing or routing operations. Your hearing can be permanently damaged if exposed to long periods of high noise levels.

DO NOT OVERREACH

Keep proper footing and balance at all times.

MAINTAIN TOOL WITH CARE

Keep tools sharp and clean at all times for the best and safest performance. Follow manufacturer's instructions for lubricating and sharpening and also for changing accessories.

DISCONNECT POWER TO THE TOOLS

Before servicing or when changing accessories always disconnect power supply to avoid accidental start up.

AVOID ACCIDENTAL START UP

Make sure switch is in "OFF" position before plugging in cable to the power supply.

USE RECOMMENDED ACCESSORIES

Consult the owners manual for details of any manufacturer's accessories or contact your supplier for details of recommended accessories. Follow the instructions that accompany the accessory. The improper use of accessories may cause hazards. The fitting of non-recommended accessories may also cause hazards.

NEVER STAND ON TOOL

Serious injury could occur if the tool is tipped or if the cutting tool is accidentally contacted. Do not store materials above or near the tool such that it is necessary to stand on the tool to reach them.

CHECK DAMAGED PARTS

Before further use of the tool, a guard or other part that is damaged should be carefully checked to ensure that it will operate properly and perform its intended function. Check for alignment of moving parts, breakage of parts, mounting and any other conditions that may affect its operation. A guard or other part that is damaged should be properly repaired or replaced. A parts list is to be found at the back of your operator's manual.

NEVER LEAVE A MACHINE RUNNING UNATTENDED

ALWAYS turn power off. Do not leave machine until it comes to a complete stop.

DRUGS, ALCOHOL AND MEDICATION

NEVER operate tools whilst under the influence of drugs, alcohol or after taking medication.

USE THE CORRECT TOOL

Do not force a tool or attachment to do a job for which it was not designed. This is dangerous workshop practice.

BASIC SAFETY FOR WOODTURNING LATHES

PLEASE READ CAREFULLY ALL THE INSTRUCTIONS IN THIS MANUAL.

The safety information in this manual is highlighted by the following safety alert symbols indicating the level of risk:-

DANGER means if safety information is not followed someone *will be* seriously injured or killed.

WARNING means if safety information is not followed someone *could be* seriously injured or killed.

CAUTION means if safety information is not followed someone *may be* seriously injured or killed.

When using this Woodturning Lathe please follow basic safety precautions including the following:-

DO read and understand this owner's manual and all labels on the woodturning lathe before operating. Use only as described in this manual. To avoid personal injury or damage to lathe use only recommended accessories.

DO place unit on a stable, level surface.

DO unplug power cord before cleaning or servicing in order to avoid injury from accidental start up.

DO turn off controls before unplugging.

DO keep hair, loose clothing, fingers and all parts of the body away from openings and moving parts.

DO connect to properly earthed power outlet only (see EARTHING INSTRUCTIONS).

DO only use this lathe for machining hard and soft woods. The maximum diameters and lengths of the workpiece are defined in the instruction manual.

DO ensure workpieces are completely free of foreign objects such as nails and screws. Also avoid knots and cracks.

DO ensure workpiece is properly secure.

DO ensure chuck key and any other wrenches and tools are removed from machine before starting machine up.

DO observe all safety labels and warnings attached to the machine and keep them clear and legible.

DO use only well sharpened, good quality woodturning tools. Replace or resharpen dull tools immediately.

DO keep all covers in place when using lathe.

DO ensure lathe is stationary and switched off before making any adjustments to tool rest, tailstock, headstock or workpiece mounting. When changing from spindle to bowl turning operations or when carrying out routine maintenance or cleaning the machine must be disconnected from the power source.

DO ensure all maintenance of an electrical nature is carried out by a qualified electrician.

DO keep a clean and tidy workshop. Store tools not being used well away from the work area. Remember, wood shavings are a fire hazard. The dust generated by wood can be injurious to health. Always site your lathe in a well ventilated area. Provide for proper dust extraction and collection as necessary.

DO NOT allow to be used as a toy. Close attention is necessary when used by or near children.

DO NOT leave the appliance plugged in. Unplug from outlet when not in use and before servicing.

DO NOT unplug by pulling on the cable. To unplug, grasp the plug, not the cable.

DO NOT use with damaged cable, plug or other parts. If your woodturning lathe is not working as it should, has missing parts, has been dropped, damaged or is defective in any other way return to Service Dealer.

DO NOT handle plug of lathe with wet hands.

DO NOT divert or distract persons working on this lathe as there is always danger to fingers and hands.

DO NOT remove or render inoperable the safety mechanisms incorporated into the lathe.

DO NOT leave the machine running unattended. Switch off and remain with the machine until it comes to a complete stop,

INTRODUCTION

We wish you every success with your APTC M900 Woodworking Lathe and stress the importance of reading and thoroughly understanding the information contained within this instruction manual. As with all machinery there are certain hazards involved, following these instructions carefully will enable you to use the machine correctly and with safety. If you do have any questions relating to its application we strongly advise you contact your supplier. In addition to the safety requirements contained within this instruction manual, you should observe the generally recognised rules governing the operation of wood-working machinery and your country's applicable regulations.

Whilst unpacking your machine, please check all components for damage or shortages, and inform your supplier immediately. Please use only genuine parts for any necessary replacements needed during the lifetime of your machine. You will find a parts list contained within this manual. When ordering parts, please use the part number, description of part and give year of purchase of machine.

IMPORTANT NOTE

In accordance with liability laws the manufacturer or supplier shall not be responsible for damage or accidents arising from the use of this machine as a result of unauthorised use; improper use; non-compliance with operating instructions; repairs made by unauthorised or incompetent persons; the installation and use of parts and replacements which have not been approved by the manufacturer or supplier; or the failure of the electrical system as a result of misuse and non-compliance with BS EN60 204-1 Part 1 (1993).

CAUTION

A copy of the instruction manual should always be kept near the machine and should be read and understood by **every operator** before beginning work. Further copies of this instruction manual are available from the manufacturer or your supplier at the cost of postage only.

PRECAUTIONS FOR SAFE AND PROPER USE

If you are unfamiliar with the use of a woodturning lathe seek advice from your supervisor, instructor or other qualified person. If you are an amateur or hobbyist woodturner just starting out on this fascinating hobby we would strongly advise joining at least a short course of professional tuition from a recognised woodturning instructor. Advertisements for courses and tutors can be found in all woodworking or woodturning magazines sold in the UK. Many local education authorities run evening classes in this subject.

A national association exists to promote interest in woodturning - The Association of Woodturners of Great Britain, Keepers Cottage, Lee, Ellesmere, Shropshire SY12 9AE.

MACHINE MOUNTING AND SITING

Choose a site for the machine in your workshop that is well illuminated and ventilated. This site should not present a hazard to people entering or leaving your workshop. Ensure the machine is mounted securely and is stable. If using a work bench to mount the lathe onto, it must be able to support a weight of 85kgs (170lbs) with sufficient rigidity to withstand the "out of balance" created in bowl turning for example.

Assemble the stand supplied in accordance with the assembly instructions. We recommend bolting the stand legs to the floor through the feet provided on the inside of the legs using proprietary 10mm (3/8") bolts. Also recommended is the addition of a shelf screwed onto the long and short cross supports. This should be manufactured out of plyboard or medium density fibre board (MDF) of 18-25mm (3/4-1") thickness. This gives a handy storage for tools and wood stock as well as providing additional rigidity to the stand.

SPECIFICATION

MODEL:	APTC M900
MAXIMUM DISTANCE BETWEEN CENTRES:	900mm (35")
CENTRE HEIGHT OVER BED:	152mm (6")
TURNING CAPACITIES BETWEEN CENTRES:	304mm (12")
BOWL TURNING CAPACITY:	456mm (18")
MOTOR POWER:	.375kw (1/2hp)
HEADSTOCK SPINDLE SPEEDS:	430, 690, 1000, 1310, 1750 & 2400rpm
HEADSTOCK SPINDLE DIMENSIONS:	Diameter 25mm (1"); Thread 8tpi; Bore 2MT
TAILSTOCK BARREL DIMENSIONS:	Bore 2MT; Travel 70mm (2 3/4")

OPERATION

POWER SUPPLY

Your woodturning lathe is pre-wired at the factory. The voltage and amperage are indicated on the label affixed to the motor and switch cover. Please read all the labels carefully before connecting the lathe to the power source. Please use a Time Delay Fuse or Circuit Breaker of the correct voltage and amperage. Failure to do so can result in injury from shock or fire and damage to the motor. Machines supplied for UK use are fitted with 13 amp moulded plug and 13 amp fuse.

Your woodturning lathe must be properly earthed. Not all power sources are properly earthed ie portable generators. If you are not sure that your power source is properly earthed, have it checked by a qualified electrician.

WARNING

If not properly earthed this woodturning lathe can cause an electrical shock particularly when used in damp conditions. If power cord is worn or damaged in any way have it replaced immediately by a qualified electrician.

EARTHING INSTRUCTIONS

This machine must be earthed. If it should malfunction or breakdown, earthing provides a path of least resistance for electrical current thereby reducing the risk of electrical shock. This machine is fitted with a cord which has a machine earthing conductor and an earthing plug (standard UK 13 amp). The plug must be installed into a power outlet that is properly installed and earthed in accordance with UK installation codes and practices.

If the power outlet source is not a standard UK 13 amp socket you must make sure that it is adequately earthed. If a properly earthed power outlet source is not available have one installed by a qualified electrician.

Improper connection of the equipment earthing conductor can result in a risk of electric shock. Check with a qualified electrician if you are in doubt as to whether or not the power source is properly earthed.

Do not modify any of the electrical components provided with the machine. If any are, or become, damaged have them replaced by your supplier or a qualified electrician.

In dry areas or when the relative humidity of the air is low static shocks are common. To reduce frequency of such shocks add moisture to the atmosphere by installing a humidifier.

ON/OFF SWITCH

When the stand is used the switch should be mounted on the left hand front stand leg. Start the lathe by pushing the green ON button. Stop by pushing the red OFF button.

Keep inexperienced persons and children away from the lathe - accidental start up can result in serious injury.

IDENTIFICATION OF COMPONENTS

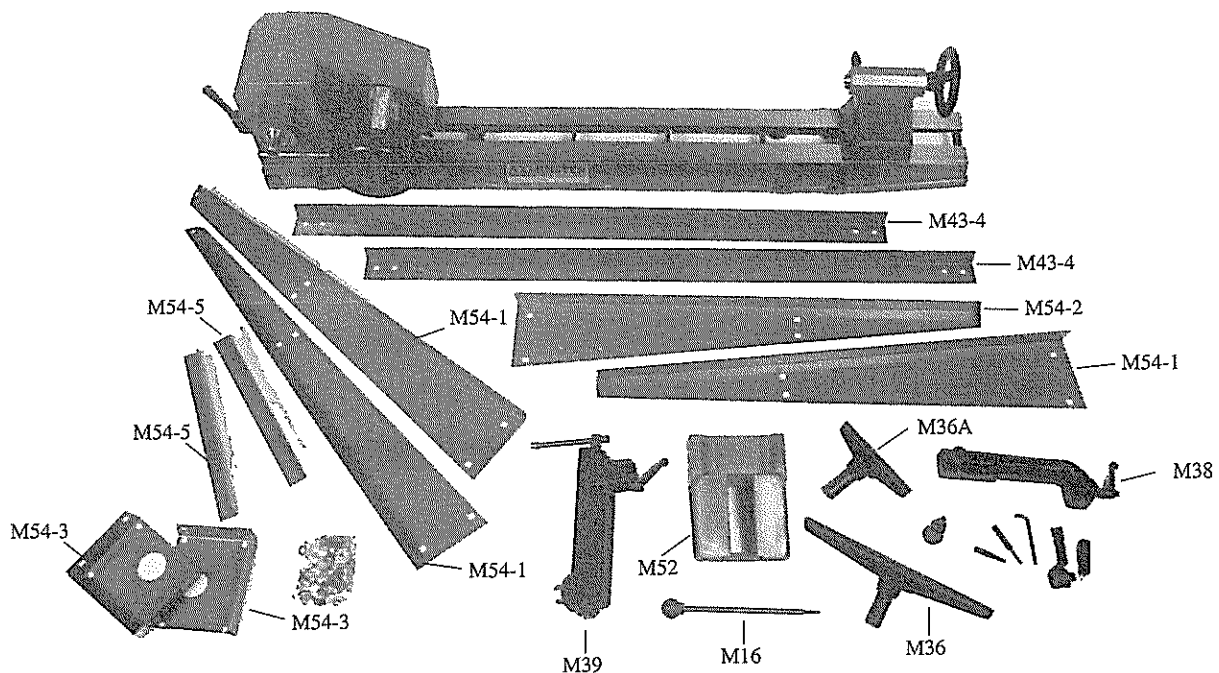

ASSEMBLY INSTRUCTIONS

- In the top tray of the box you will find the following components (refer to parts diagram):-
 - 3 off M54-1 Stand Leg
 - 1 off M54-2 Stand Leg for Switch
 - 2 off M54-3 Stand Upper Cover
 - 2 off M43-4 Stand Long Cross Support
 - 2 off M54-5 Stand Short Cross Support
 - 1 off M16 Pin-Injection
 - 1 off M36 Tool Rest
 - 1 off M36A Tool Rest
 - 1 off M38 Extension Rest

Lift components out of tray, place together on a suitable flat floor space.

2. Decide now if you wish to use the stand supplied with the lathe. If not, go straight to Section 9.
3. Remove top tray from box. Find plastic bag of nuts and bolts in box. The stand is assembled by making up the leg assemblies from two stand legs and one upper stand cover for one end. Then one stand leg, one stand leg for switch and one upper cover for the other end. Bolt them together using cup square bolts, flat washers, spring washers and nuts. Do not fully tighten at this stage.

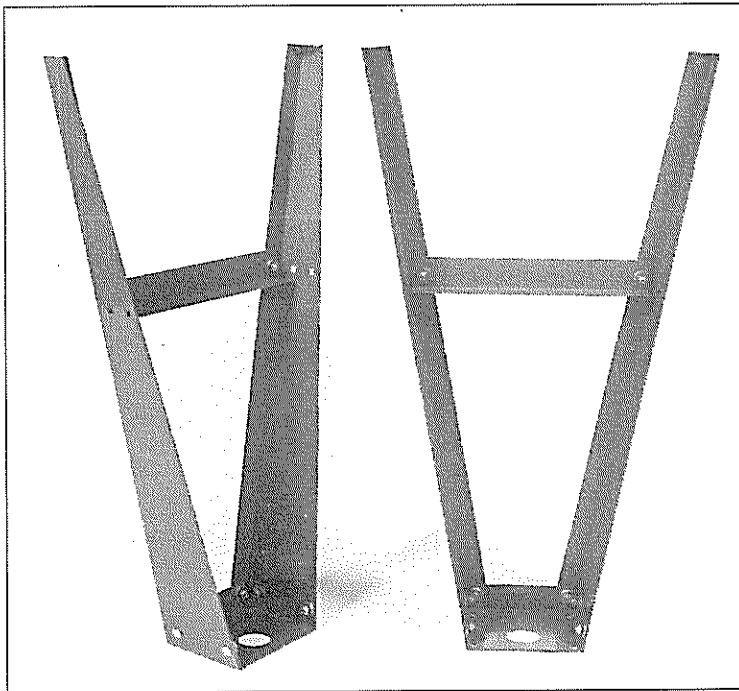
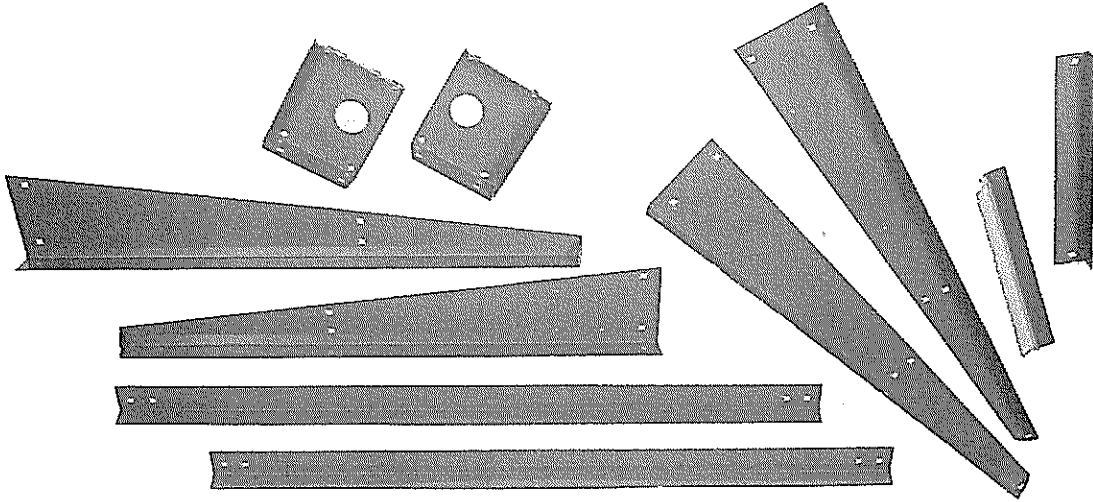

4. Bolt one stand short cross support into each end.

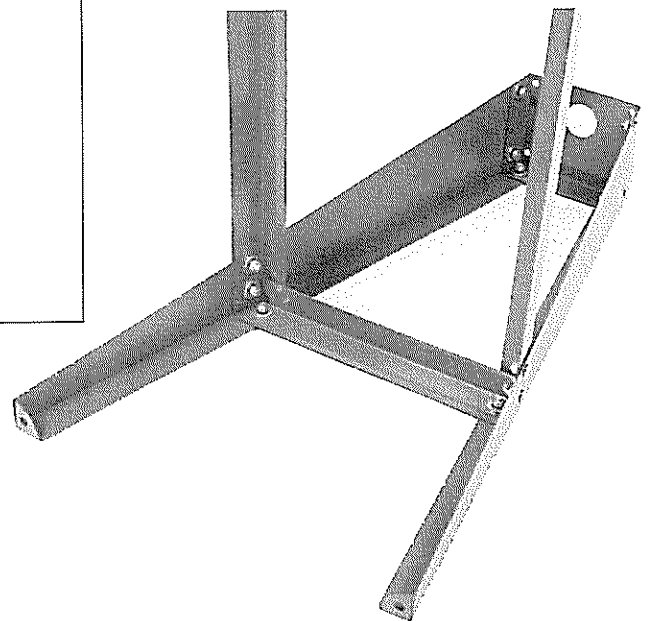

5. Lay one end flat and bolt two stand long cross supports into it as shown.

6. Put this end upright and bolt the stand long cross support into the other end.

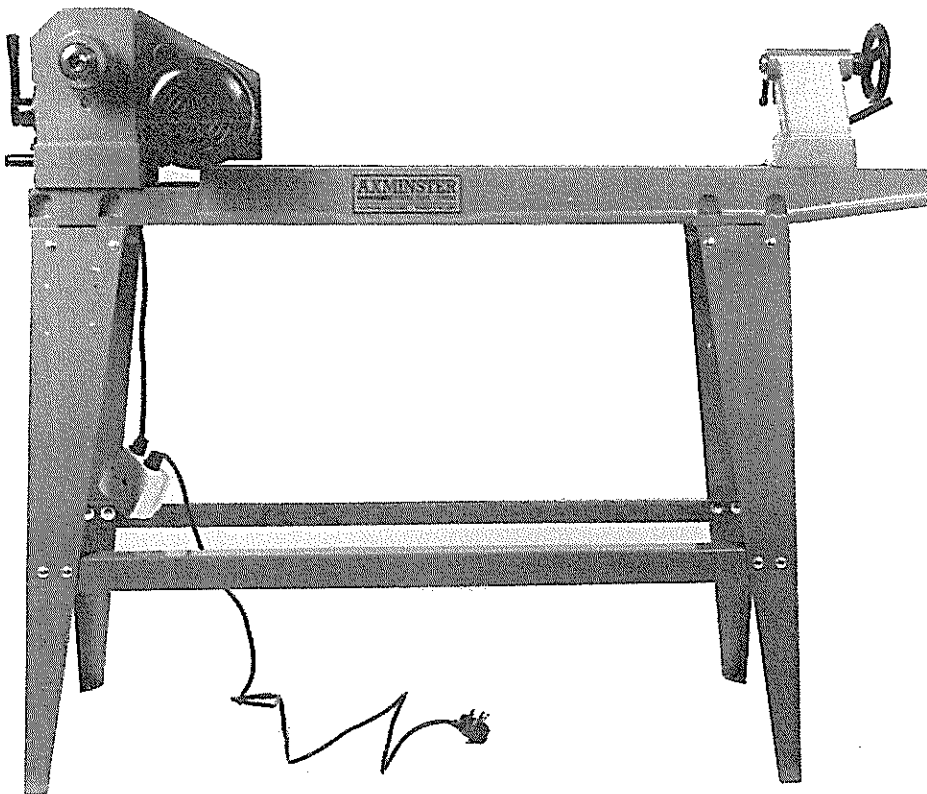
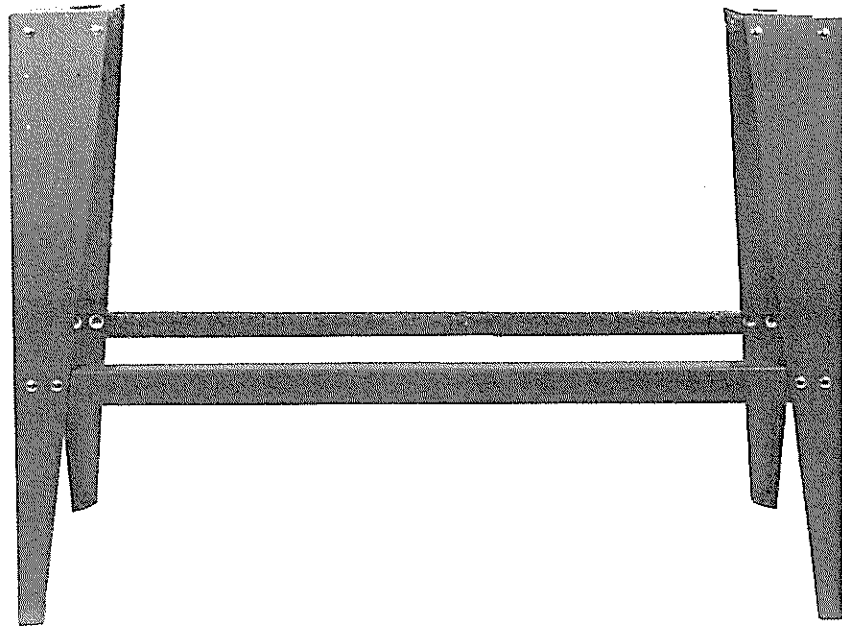

7. Now place the stand where you wish to use the lathe (if possible) with the switch mounting facing you and on the left hand end of the stand. Get an assistant to help you lift the main body of the lathe out of the box. Place the lathe onto the stand with the headstock on the left hand (switch) end. Take care not to trap the cable.

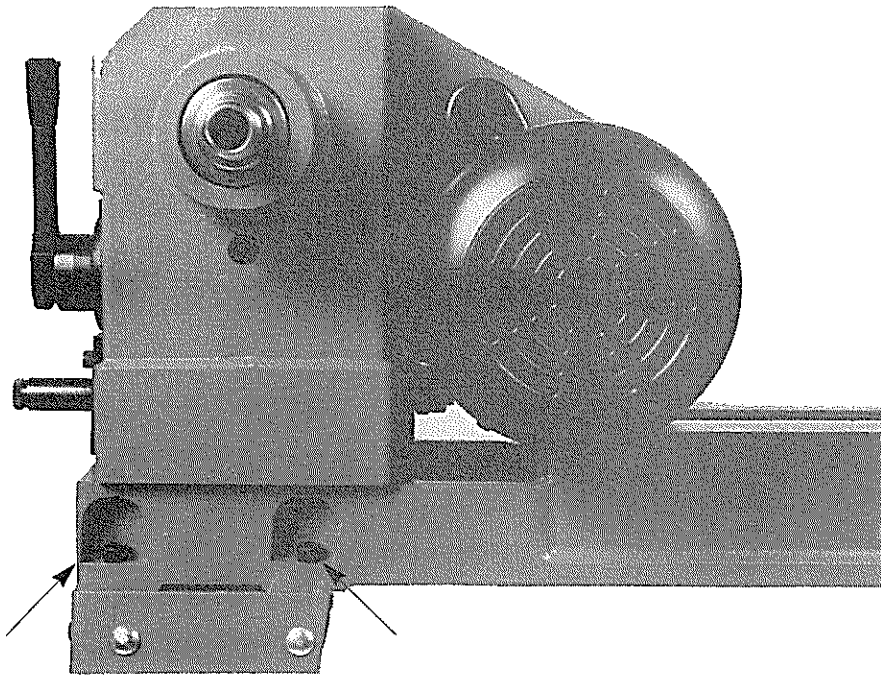

8. Line up the four mounting bolt holes in the lathe bed with the corresponding holes in the stand at the headstock end and secure with four Allen bolts, spring washers and nuts. Now repeat at the tailstock end - you will find a special Allen key in a bag in the box. Now tighten all stand bolts.

9. If you are not using the stand place the lathe onto a suitable, sturdy work bench with the headstock to your left, again taking care not to trap the cable. Bolt down securely with suitable bolts.

10. Now secure extension bed (M52) onto holes in headstock end of bed with two Allen bolts and washers.

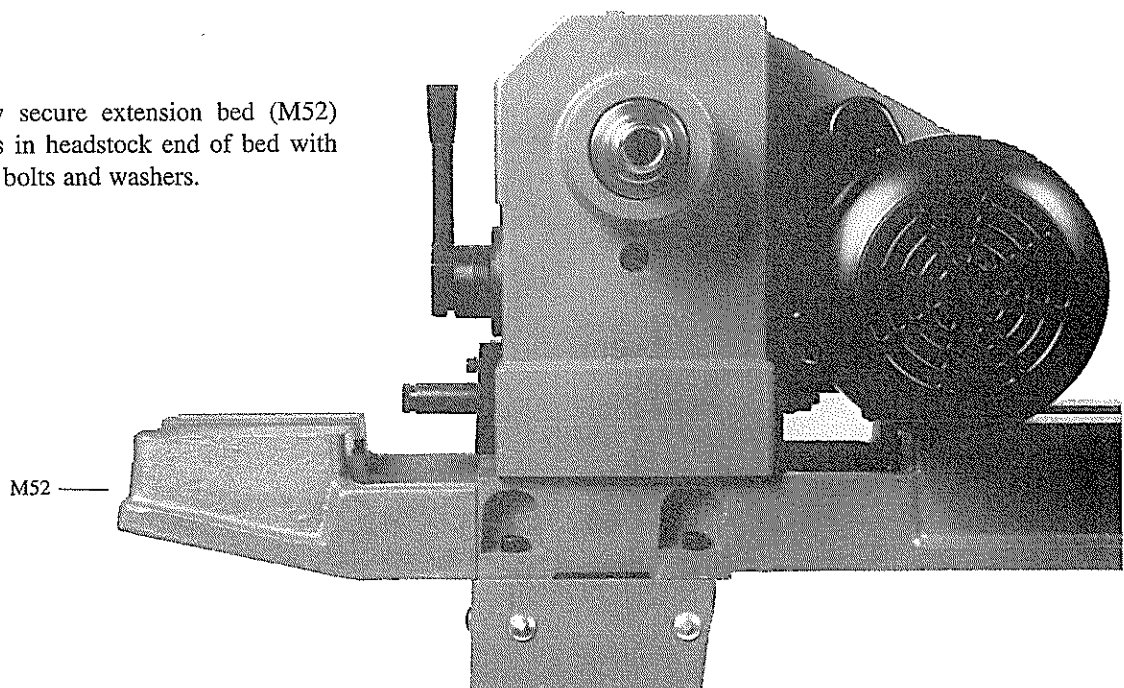

10. Install angular setting assembly (M35) into rear of headstock. Tighten with spanner.



11. Install handle onto clamping bar, below speed change lever, with screw and spring.

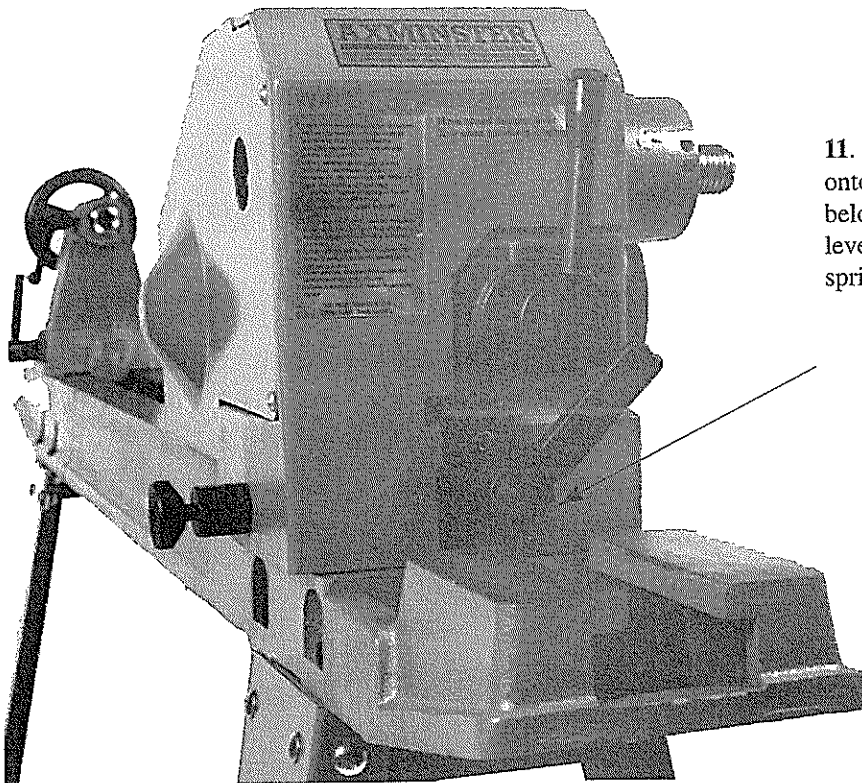

ON/OFF SWITCH

The M900 Lathe is fitted with a No Volt Release (NVR) Switch for your safety. This unit does not require any maintenance. The earth connection is contained within the switch body. The 3 pin 13 amp plug must be fitted with a 13 amp fuse. Press the Green button and the headstock spindle will rotate in an anti-clockwise direction when viewed from the spindle nose. Press the Red button and the spindle should stop immediately. If the current supply should be interrupted whilst the motor is running the motor will not re-start until the Green button is pressed after the current supply has been restored.

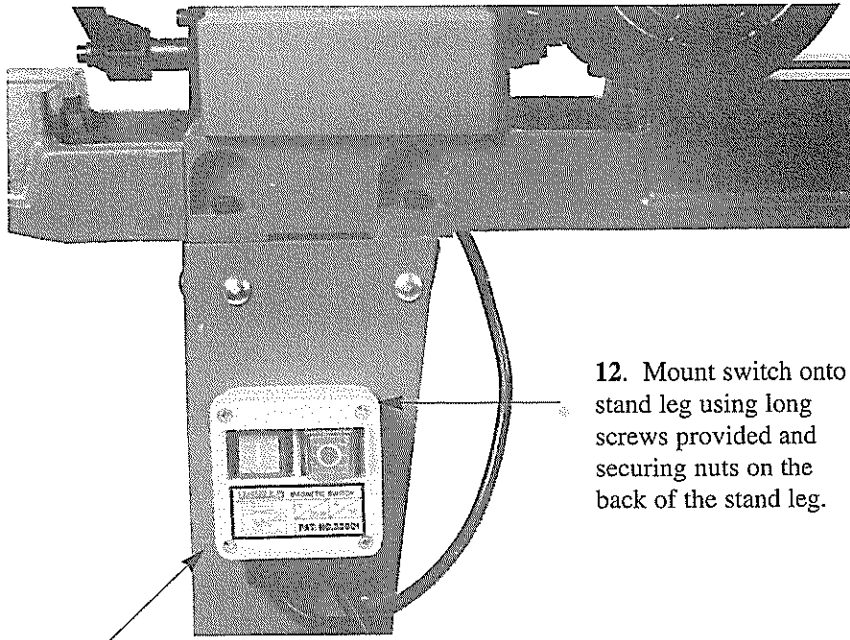

12. Mount switch onto stand leg using long screws provided and securing nuts on the back of the stand leg.

13. Unpack tool rest body, remove the nut and large washer. Place the body on the lathe bed with tommy bar towards you and with the bolt between the bed bars. Refit washer and nut. With tommy bar horizontal, tighten nut fully by hand, then loosen nut by 1/4 turn. The tool rest body should move freely by hand on the lathe bed but should lock firmly when tommy bar is moved towards vertical. If necessary remove any paint from underside of tool rest body to ensure firm clamping action onto bed and casting.

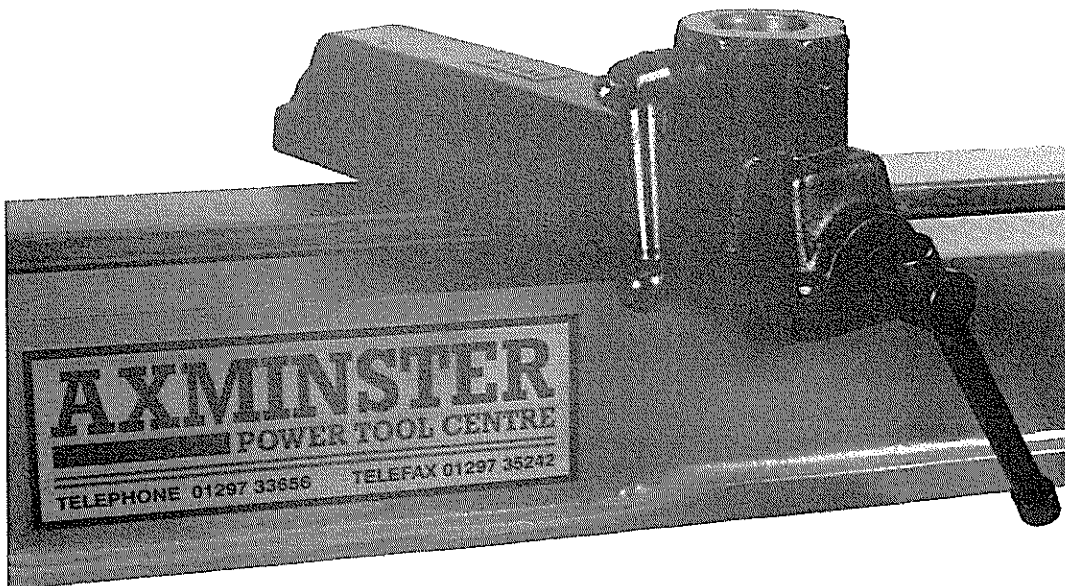

14. The tailstock should slide freely with the side mounted locking lever on its rest. If not, slightly undo the nut located between the lathe bed bars beneath the tailstock. The tailstock should lock the lever raised approximately 45°. Fit the handwheel knob (See D Fig 3 on Page 12). Your machine is now complete and ready to use.

OPERATION OF CONTROLS

SPEED SELECTOR (A Fig 1)

The speed selector lever allows the selection of one of six speeds. Select desired speed by easing the lever outwards to release the detent pin and move lever in the desired direction i.e. clockwise for higher speeds, anti-clockwise for lower speeds. Release lever and the detent pin will hold desired speed. You may need to move the lever slightly either way to line up a hole in the lever backplate with the detent pin.

CAUTION

Never change speed without the motor running. Damage to the drive belt or pulleys can occur. Always try to stop machine on the slowest speed as this relieves stress on the drive system on start up.

HEADSTOCK POSITION LOCK

(B Fig 1)

This lever locks the headstock in a fixed position. Tighten clockwise to lock. Loosen anti-clockwise to unlock. This is used in conjunction with the DETENT RELEASE knob (C Fig 1).

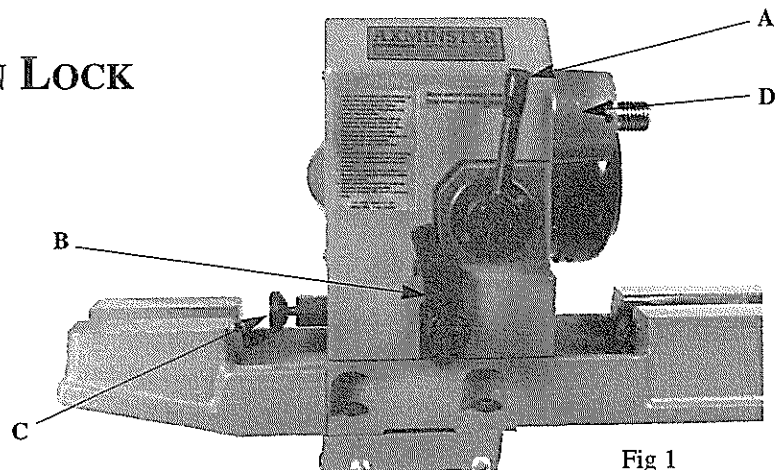

Fig 1

HEADSTOCK SHAFT LOCKING OR INDEXING

Machines supplied after late 1996 will include a modified headstock casting to accommodate two holes in the casting nose (D Fig 1). One is threaded and can be used for locking the headstock shaft for the removal of faceplates, chucks etc by fitting the locking pin provided. The pin will fit into one of twelve corresponding holes in the headstock shaft that must be lined up before tightening the pin. The other hole is offset at 15° and allows a further 12 divisions giving 24 position indexing. A plain pin is also provided.

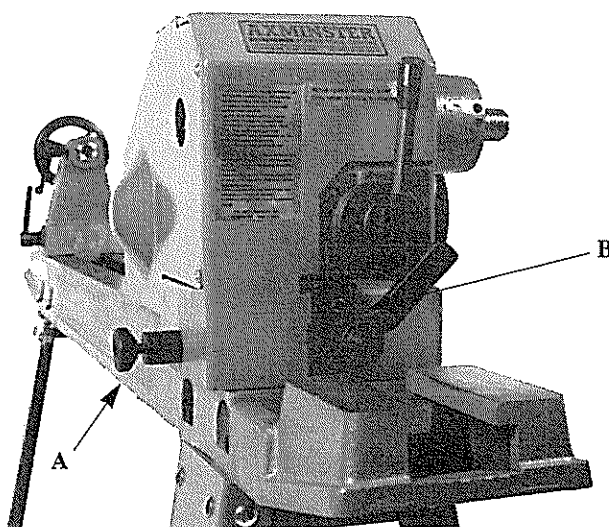

Fig 2

DETENT RELEASE (A Fig 2)

Pull out the knob after unlocking the headstock locking lever. This will enable you to swivel the headstock in relation to the lathe bed. The headstock has angles of 0°, 60°, 90°, 120° and 180° indexed onto the turntable and can be held at these angles by releasing the detent knob at the appropriate angle. Always lock the headstock into place using the headstock rotation lock (B Fig 2) before using the lathe.

TAILSTOCK HANDWHEEL (A Fig 3)

Turn clockwise to move tailstock spindle forwards. Turn anti-clockwise to retract spindle. This action will also eject any accessory held in the tailstock taper.

TAILSTOCK SPINDLE LOCK (B Fig 3)

Locks tailstock spindle. Undo before adjusting tailstock handwheel.

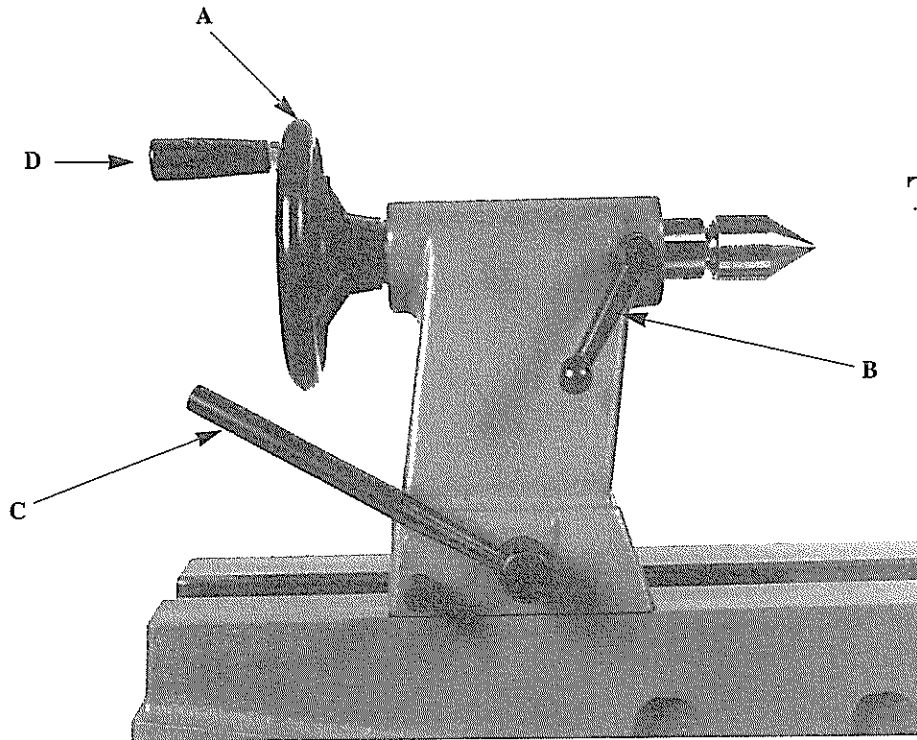

Fig 3

TAILSTOCK LOCK

(C Fig 3)

Locks tailstock into position on lathe bed. Release lever onto its rest to allow tailstock to be moved closer to or further from headstock.

For adjustment procedure, refer to Assembly Instructions.

USE OF EXTENSION BED AND TOOL REST EXTENSION

Remove tool rest from tool rest holder. Move "tommy bar" to horizontal to unclamp tool rest holder from lathe bed. Slide tool rest holder into gap at headstock end of bed. You can then transfer the tool rest holder (A Fig 4) onto the extension bed (B Fig 4). You may need to adjust nut underneath the tool rest holder to enable it to be clamped to the extension bed. Rotate the headstock to the desired angle for outboard turning (C Fig 4). In most instances the tool rest extension (C Fig 4) will be used to fully extend the lathe's turning capacity.

Fig 4

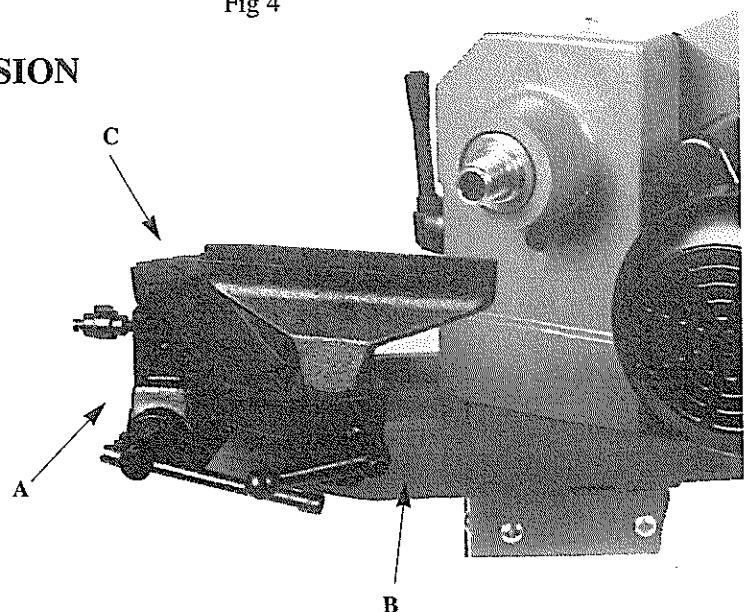

MAINTENANCE

HEADSTOCK MAINTENANCE

The headstock bearings are greased for life and require no maintenance. You will need to remove the belt cover to change the belt or lubricate the drive pulley. It is best to lubricate the drive pulley system after removing the belt.

BELT CHANGING

Stop machine on the slowest speed. Unplug power supply cable. Remove belt cover. Move speed selection lever to "fast" position. Remove the belt from the headstock shaft pulley, then slip the belt from motor pulley. This pulley will now close together. If you wish to lubricate the headstock shaft pulley, now is the best time to do it. All that is required is to spray a PTFE dry lubricant (see below under Bed Maintenance) BETWEEN the pulley halves. Move speed selection lever to "slow" position and spray the headstock shaft between the pulley and headstock casing. Also, on the end of the motor shaft there is a small grease nipple which is used to lubricate the sliding half of the motor pulley. This will also need greasing periodically.

To fit a new belt you will need to prise open the motor pulley, either with your finger-tips or with a pair of medium flat bladed screwdrivers held on opposite sides of the pulley. Holding the pulley apart, slip the new belt over the pulley. Now make sure that the speed selection lever is in "fast" position, slip the belt over the headstock shaft pulley. Re-fit the belt cover and start the lathe. Move the speed selection lever through its range to check that the speed range is being attained and to settle in the new belt.

MOTOR MAINTENANCE

The motor bearings are also greased for life. The motor itself needs no maintenance except for periodic cleaning. Firstly, unplug power supply cable. Remove the three end cover screws and remove cover. With a vacuum cleaner and a small paint brush, remove all accumulations of dust. Re-fit cover securely.

WARNING

These motors are surface cooled and have an operating temperature of 60° centigrade. Placement of hands upon a running motor is not recommended. It is quite natural for a new machine to "smell" hot when it is run for any length of time early in its life.

TAILSTOCK MAINTENANCE

It is advisable that the tailstock barrel is removed periodically to grease the internal thread. This is done by undoing the tailstock spindle lock three or four turns and rotating the handwheel clockwise until the barrel no longer moves out. You can then withdraw the barrel from the tailstock, clean out any contamination and re-grease with a light grease. The outside of the barrel can also be lightly smeared with grease. Refit the barrel into the tailstock until the thread locates onto the tailstock screw and rotate the hand wheel anti-clockwise. Make sure that the keyway locates in line with the tailstock spindle lock.

BED MAINTENANCE

The top surface of the bed is unprotected against corrosion and so will need care to prevent rust forming on the surface. Obviously, a wipe down with an "oily rag" will do the job, but it will probably need cleaning off before you next use the lathe. Our personal preference is to use a multi-use synthetic lubricant with TEFLON*. This will put a micronized layer of PTFE on the bed, providing a very low co-efficient of friction and preventing sticking, reducing wear, repelling moisture and fighting corrosion. This type of lubricant can be used with great effect on virtually anything that moves! APTC sell TEFLON* please contact APTC Sales Office (01297 33656) for further details.

* TEFLON is a registered trademark of DuPont Nemours & Co Inc

TROUBLE SHOOTING

PROBLEM

SOLUTION

Spindle does not run at high speed.

Check condition of belt, replace if worn.
Motor pulley not closing properly. Refer to pulley lubrication in Maintenance Section.

Tailstock or tool rest holder does not lock into place.

Securing nut underneath bed is too loose. With locking handles in unlock position, tighten nut fully home by hand and undo by approximately 1/4-1/2 turn.

Tailstock handle stiff to turn.

Tailstock locking lever still secured. Tailstock barrel needs greasing. Refer to Maintenance Section.

Motor will not turn.

Fuse blown. Replace with 13 amp BS1362 fuse.
Switch not operating. Have switch repaired by a suitably qualified person or return unit to your Supplier.
Motor capacitor failed (inspection will reveal bulging, leaking or split in casing). This can be caused by inability of motor to turn because of mechanical seizure of headstock shaft or drive system. Check that shaft can be turned freely.

Drive centres do not run true when installed in headstock shaft.

Wood shavings or dust trapped inside headstock shaft taper. Clean out with a clean cloth. Do not leave any oil or grease residue inside the shaft taper.

Drive system "chatters" at certain speeds.

Check tightness of grub screws locating the fixed halves of the drive pulleys on the motor and headstock shafts

Vibrating or noisy lathe headstock.

Usually caused by a poorly joined belt or failing headstock shaft bearings. Fit a new belt (refer to Maintenance Section) or return unit to your supplier to have new bearings installed.

WIRE CONNECTION

WARNING

All electrical work or wire connection should be carried out by a qualified electrician.

For wire connections refer to electrical components list and wiring diagram below.

Electrical Components List

Item	Function	Technical Data	Quantity	Supplier	In Compliance With (Standard)
K.M.L	Contactora	4A	1	ShenDian	IEC158-1
T.R.	Overload Relay	C.T.-4.2A 8		ShenDian	IEC292-1
Source Wire		1.0mm	1	Ta Hsing	V.D.E.
Motor Wire		1.0mm	1	Ta Hsing	V.D.E.
Cable		6-13	2	K.S.S.	

WIRING DIAGRAM FOR LATHE WITH SINGLE PHASE MOTOR

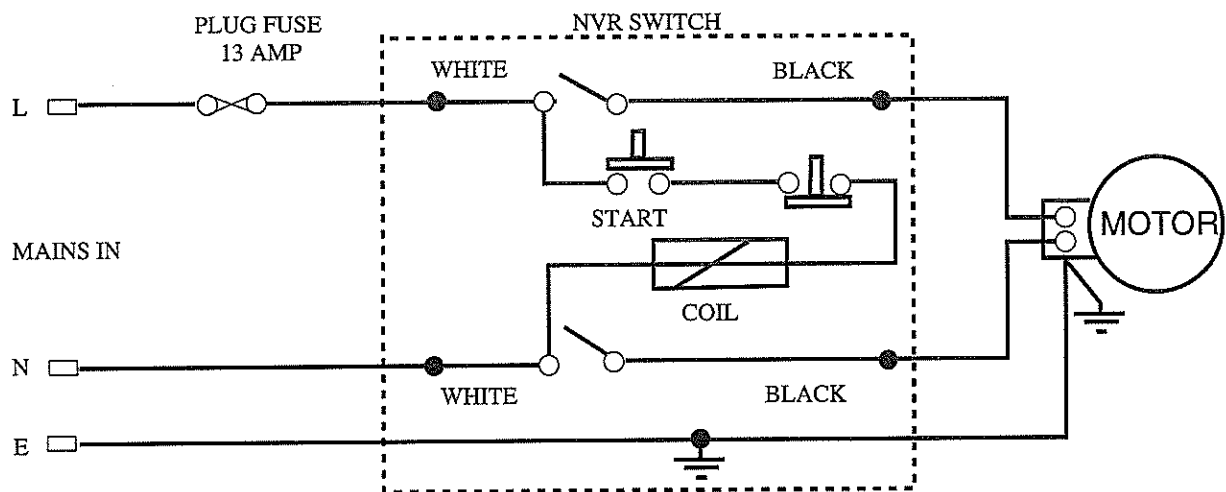

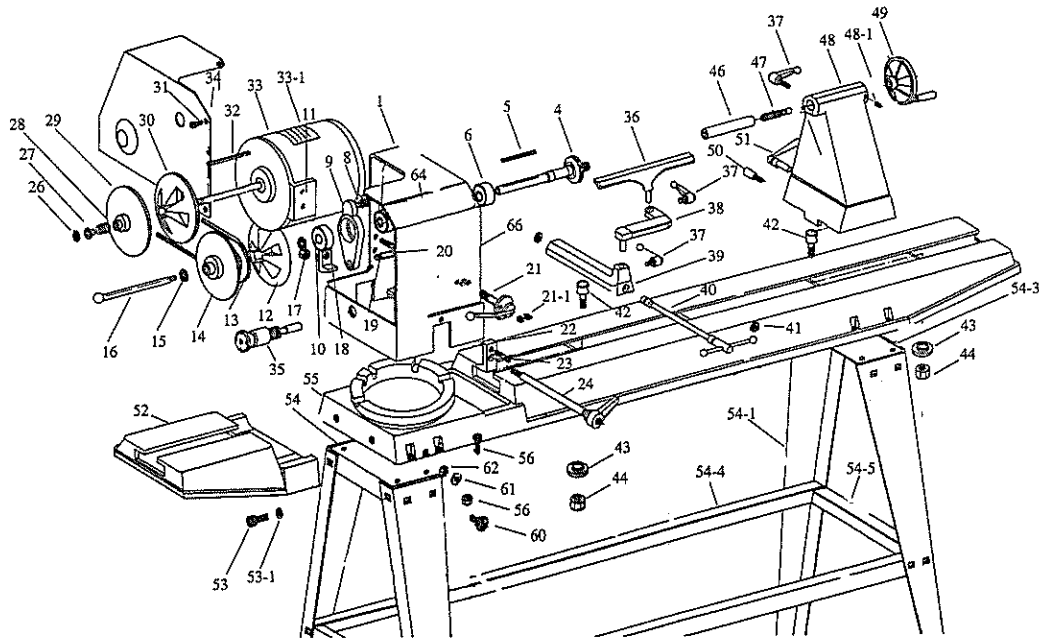

APTC M900 PARTS LIST

INDEX NO	PART DESCRIPTION	QTY	INDEX NO	PART DESCRIPTION	QTY
M1	HEADSTOCK	1	M36	TOOL REST	1
M4	SPINDLE	1	M37	HANDLE ASSEMBLY	3
M5	KEY 4 x 4 x 85mm	1	M38	EXTENSION REST	1
M6	BEARING 6205ZZ	1	M39	TOOL REST BODY	1
M7	BEARING 6205ZZ	1	M40	ECCENTRIC ROD	1
M8	SPRING	1	M41	"C" RING-S16	2
M9	BEARING YOKE	1	M42	BOLT	2
M10	BEARING 6006Z	1	M43	CLAMP	2
M11	"C" RING S-25	1	M44	HEX NUT 3/4"	2
M12	PULLEY-RIGHT HALF	1	M46	TAIL SPINDLE	1
M13	DRIVE BELT Z22	1	M47	TAILSTOCK SCREW	1
M14	PULLEY-LEFT HALF	1	M48	TAILSTOCK	1
M15	"C" RING S-24	1	M48-1	SOCKET SCREW	1
M16	PIN-INJECTION	1	M49	HANDLE	1
M17	LOCK NUT 1/2"	1	M50	LOCK HANDLE	1
M18	CLAMP-LEFT	1	M51	BOLT	1
M19	SCREW 5/16" x 3/4"	1	M52	EXTENSION BED	1
M20	RACK	1	M53	SCREW 3/8" x 1"	2
M21	GEAR ASSEMBLY	1	M53-1	SPRING WASHER	1
M22	CLAMP-RIGHT	1	M54	STAND ASSEMBLY	1
M23	SOCKET SCREW	1	M54-1	STAND LEG	3
M24	KNOB	1	M54-3	UPPER COVER	2
M26	"C" RING S-16	1	M54-4	LONG CROSS SUPPORT	2
M27	SLEEVE	1	M54-5	SHORT CROSS SUPPORT	2
M28	SPRING	1	M55	BED	1
M29	PULLEY-RIGHT HAND	1	M56	SCREW 5/16" x 1"	8
M30	PULLEY-LEFT HAND	1	M60	BOLT 5/16" x 3/4"	24
M31	SCREW 3/16" x 3/8"	4	M61	WASHER	24
M32	KEY 4 x 4 x 85mm	1	M62	NUT 3/16"	24
M33	MOTOR	1	M64	LOGO LABEL	1
M33-1	NAME PLATE	1	M66	SPEED LABEL	1
M34	MOTOR COVER	1			
M35	ANGLE SETTER	1			

N.B. For a revolving centre (APTCRC2) and drive centre (APTC412) see APTC Catalogue.

DECLARATION OF CONFORMITY

We Axminster Power Tool Centre
Axminster
Devon
EX13 5HU

declare under our sole responsibility that the product

Trade Name: APTC
Type No: M900/M950/M1000
Description: Woodturning Lathe

is in conformity with the following directives:

low voltage directive 73/23/EEC as amended by 93/68/EEC

machinery directive 89/392/EEC as amended by 93/60/EEC

EMC directive 92/34/EEC as amended by 93/68/EEC

Year CE Mark Affixed 1997

Name of Authorized Person Mr K Thompson

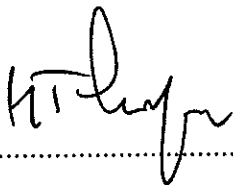
Signature of Authorized Person.....



Axminster Power Tool Centre
Axminster Devon
EX13 5HU

